

AutoTransfer Switch (ATS)

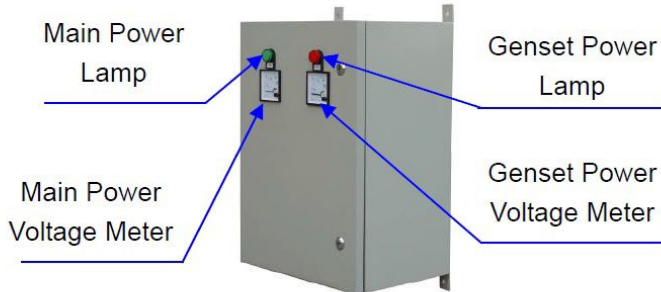

20~250A
Wall hanging type

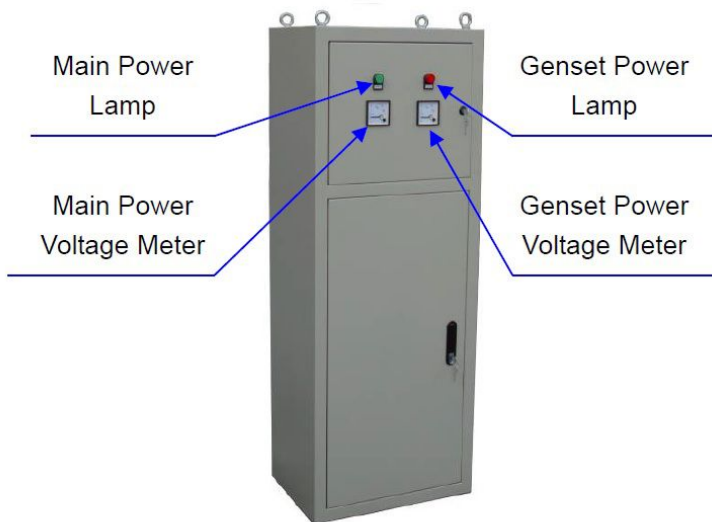

400~3200A
Vertical type

1. ATS switch choice



Standard (AISIKAI or SUYANG)



Options (SOCOMEK or ABB)

2. Main technical parameters

Standard compliance: IEC947-6-1/GB14048.11-2002

Conventional thermal current I_{th}		20A	40A	63A	80 A	100 A	125 A	160 A	250 A	400 A	630 A	800 A	1000 A	1250 A	1600 A		
Rated isolation voltage U_i		750V								1000V							
Rated impulse withstand voltage U_{imp}		8KV								12KV							
Rated operational voltage U_e		AC440V															
Rated operational current I_e	AC-31A	20	40	63	80	100	125	160	250	400	630	800	1000	1250	1600		
	AC-35A	20	40	63	80	100	125	160	250	400	630	800	1000	1250	1600		
	AC-33A	20	40	63	80	100	125	160	250	400	630	800	1000	1250	1600		
Rated making capacity		10Ie															
Rated breaking capacity		8Ie															
Rated conditional short-circuit current		100KA								70KA			100KA		120KA		
Rated short-time withstand current		7KA						9KA		13KA		26KA		50KA			
Conversion time		0.45S								0.6S		1.2S					
Control power supply voltage		AC220V															
Rated control voltage	Startup	300W						325W		355W		400 W	440W				
	Normal	55W						62W		74W		90 W	98W				
Weight(kg) Grade 4		7.0	7.2	7.2	7.2	7.5	7.5	8.8	9	16.5	17	32	36	40	43		

3. General Specification

For emergency power in building or other circumstances, Auto Transfer Switch (ATS) is essential. ATS can automatically transfer load between the main power and the emergency power (generating set) without operator. When the main power fails or voltage drop below 80% of normal voltage, the ATS will start emergency generating set after a preset time 0-10 seconds (adjustable), and transfer the load to emergency power(generating set). Contrarily, when the main power recover normal, the ATS will transfer the load form the emergency power (generating set) to the main power, and then stop the emergency power(generating set).

3. Switch structure description

1. Electric key lock: To control the power supply of the internal control circuit of the switch; when the electric lock is unlocked, automatic and remote operation is realized; when the electric lock is locked, only manual operation can be performed.
2. Operation handle: If the operation handle is to be used for operation, the electric lock should be locked.
3. Mechanical padlock: When the equipment is to be repaired, use the operation handle to put the switch in its 0 grading, pull the padlock upward and get it locked before beginning the repair (pulling the padlock upward means to cut off the internal control power supply of the switch and the switch is now in on way to be operated electrically or manually).
4. Position indication: To show the positions of the switch operation status (I. 0. II)
5. Control voltage: Switch control voltage grade: 220VAC.
6. Main body of switch: The front parts is channel I, connected to the “ commonly used power supply” the rear part is channel II, connected to the “standby power supply”.

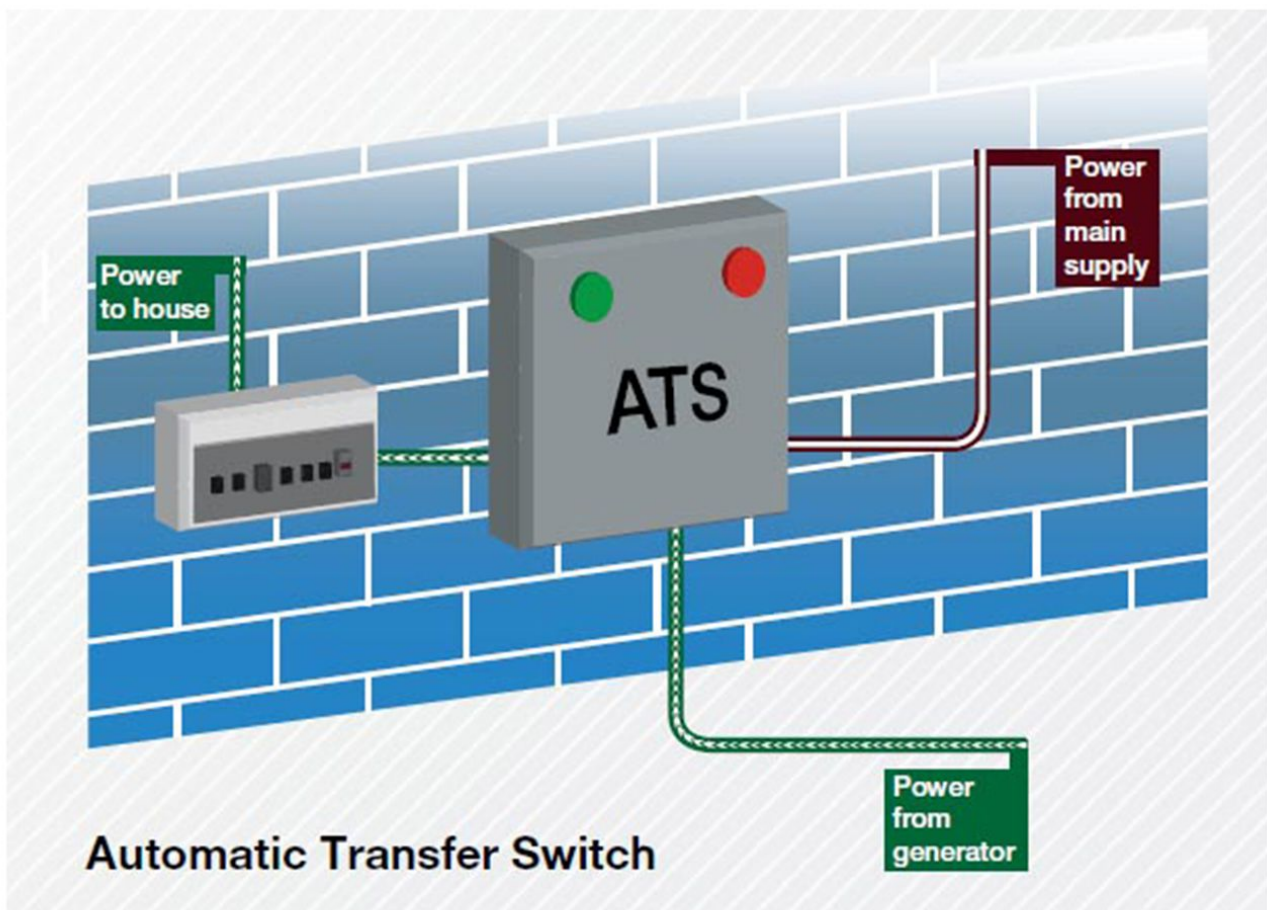

4. Typical connection - SYK1 Remote connection mode

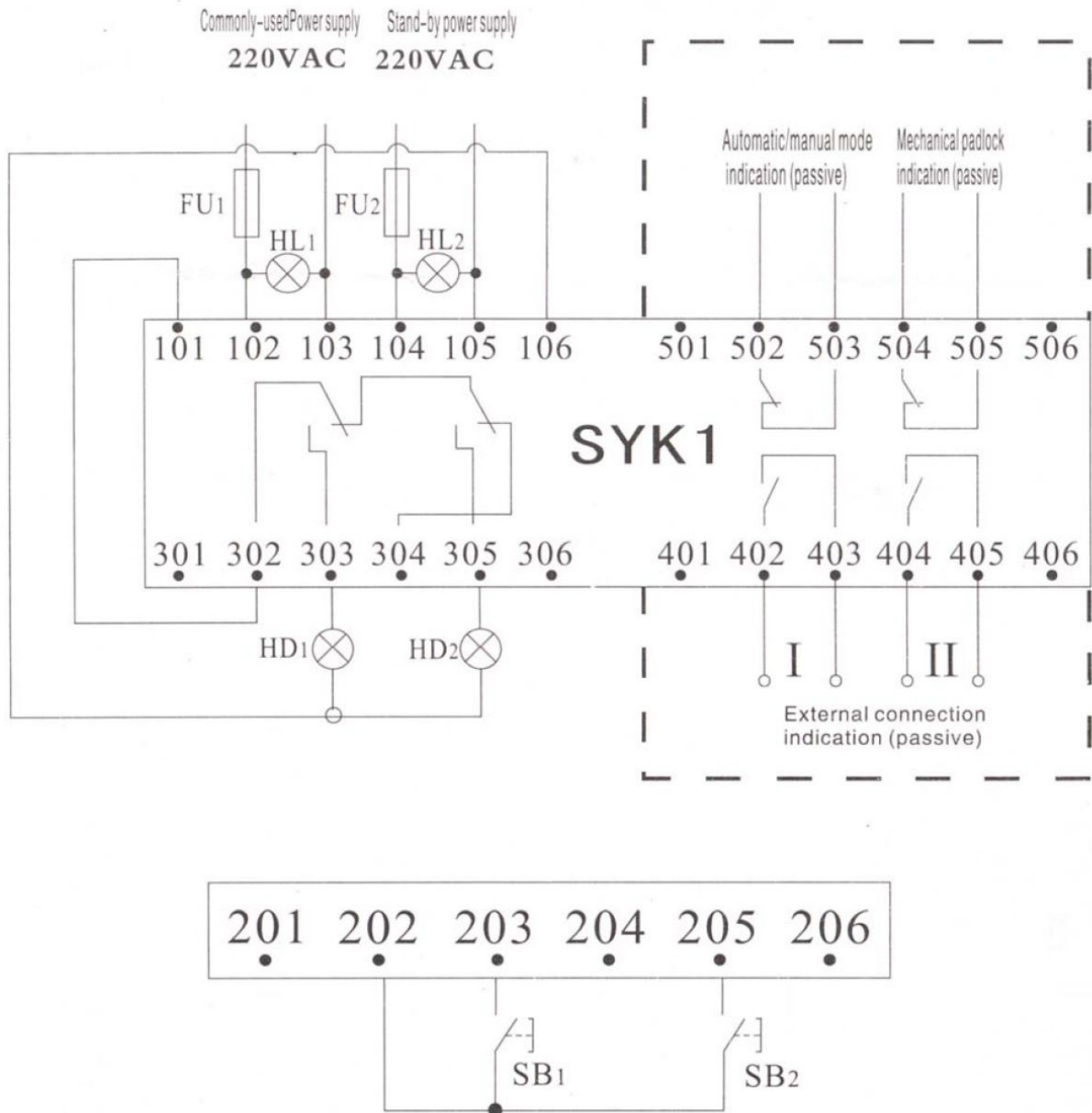

- ☆ SB1 and SB2 are manual throw-in buttons for commonly-used power supply and stand-by power supply respectively (passive contact)
- ☆ 401-406, 501-506 are switching terminals available for application.

5. The model and dimension

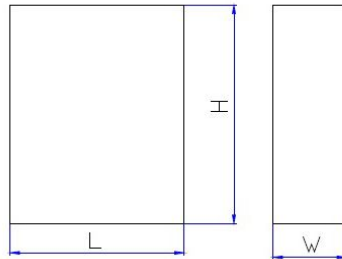

Rated current	Dimension (mm)			Rated current	Dimension (mm)		
	L	W	H		L	W	H
20A	500	340	680	630A	600	400	1450
40A	500	340	680	800A	800	600	1800
63A	500	340	680	1000A	800	600	1800
80A	500	340	680	1250A	800	600	1800
100A	500	340	680	1600A	800	600	1800
125A	500	340	680	2000A	800	800	2000
160A	500	340	680	2500A	800	800	2000
250A	500	340	680	3200A	800	800	2000
400A	600	400	1450				