

# GLT4000-8HY

Powered by  **YANMAR**

**Genlitec**<sup>®</sup>  
Power & Lighting Solutions



## ■ Generator Specification

Service	50Hz	60Hz
Genset PRP <sup>(1)</sup> (KW)	7.0	8.0
Engine speed	1500RPM	1800RPM
Power factor	1.0	
Phase	Single	
Voltage (V)	110/220; 120/240; 220; 230; 240	

## Performance Data

Model	GLT4000-8HY
Engine brand	<b>YANMAR</b>
Engine model	3TNV76
Speed control type	Mechanical
Alternator brand	<b>GENLITEC</b>
Alternator model	S164LT8
Control system	<b>SMARTGEN HGM1790N</b>
Starter motor voltage	12V
Max. height of mast	8 meters
Mast lifting/lowing system	Hydraulic
Total power of lamps	4x1000 watts <b>MH</b>
Fuel consumption (100% load)	2.5L/H
Fuel tank capacity	115L



GENLITEC Power lighting towers & generator sets are compliant with ISO 9001 and CE standard, which include the following directives:

- 2006/42/EC Machinery directive
- 2014/30/EU Electromagnetic compatibility directive
- EN 12100:2010; EN ISO 8528-13:2016; EN 60204-1:2018; EN 61000-6-2:2019; EN 61000-6-4:2019

### (1) PRP (Prime Power)

According to ISO 8528-1, prime power is the maximum power available during a variable power sequence, which may be run for an unlimited number of hours per year, between stated maintenance intervals. The permissible average power output during at 24 hours period shall not exceed 80% of the prime power. 10% overload available for governing purposes only.

### (2) ESP (Standby Power)

According to ISO 8528-1. It is defined as the maximum power available, under the agreed operating conditions, for which the generating set is capable of delivering for up to 500 hours of operation per year (of which no more than 300 hours for continuative use) with the maintenance intervals and procedures being carried out as prescribed by the manufactures. No overload capability is available.

## Container Loading Capacity

**4 SETS** (disassembled\*\*) / 20GP

**8 SETS** (disassembled\*\*) / 40GP



\*\*dismounted parts: tow bar, wheels, axle, stabilizers

### Standard Reference Conditions

Note: Standard reference condition 25°C (77°F) air inlet temp. 100m (328ft) A.S.L 30% relative humidity. Fuel consumption date with diesel fuel with specific gravity of 0.85 and conforming to BS 2869: 1998 Class A2

## Dimension & Weight

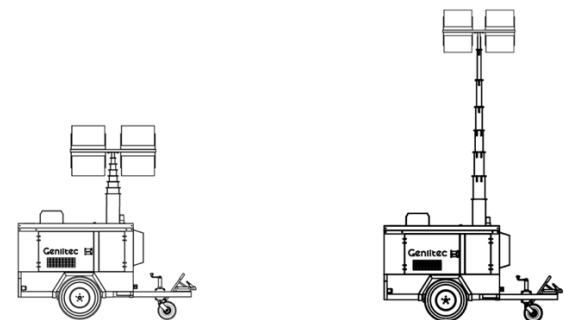

Dimension	Storage	Working
Length (L)	2810mm	2810mm
Width (W)	1440mm	2450mm
Height (H)	2890mm	8500mm
Net Weight	950kg	

Note: This parameter allows for some acceptable deviations.

# GLT4000-8HY

Powered by  **YANMAR**

**Genlitec**<sup>®</sup>  
Power & Lighting Solutions

## ■ Engine Specification

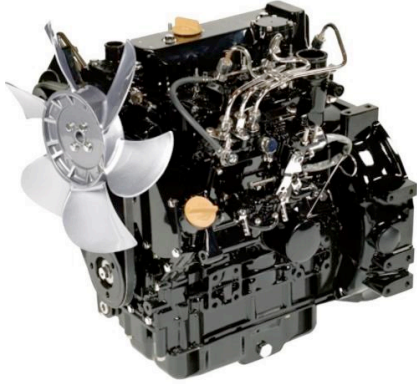

### MODEL: YANMAR 3TNV76

Cylinder number	3
Aspiration system	Natural
Cooling method	Water cooled
Combustion system	Ball-type swirl chamber
Bore x Stroke (mm)	76 x 82
Compression ratio	23.5:1
Rated speed (RPM)	1500/1800
Displacement (L)	1.116
Rated power (KW)	8.2/1500RPM 9.8/1800RPM
Coolant capacity (L)	0.9 (engine only)
Oil capacity (L)	3.4
Speed governor	Mechanical
Starter motor capacity	DC 12V

## ■ Alternator Specification



### MODEL: GENLITEC S164LT8

Number of phases	Single
Rated power (KW)	8
Frequency (Hz)	50/60
Power factor (Cos Phi)	1
Temp. rise	125K
Insulation type	H class
Ambient temp.	40°C
IP rating	IP23
Excitation system	Self-excited
Bearing	Single bearing
Coating	Vacuum impregnation
Voltage regulator	A.V.R
Coupling	Flexible disc

## ■ Operation Mast Specification

Max. height of mast	8m
Elevation system	Hydraulic
Raising/Lowering mast method	Electric Button
Mast stages	8
Mast turning angle	358° manually
Lights tilting angle	0
Mast material	Galvanization Steel tube

○ **For options** (please contact with GENLITEC sales team for more information)

## ■ Lamps Specification

Total power of lamps	4 x 1000 watts
Lamps type	Metal halide
Light capacity	4 x 75000 lumen
Design lifetime	10000 hours
Working temperature	-30~40°C
Max. Light coverage	5 ~ 7 acres
Protection grade	IP65

## ■ Chassis Specification

Tow Hitch type	"O" ring or Ball tow hitch
Brake type	Mechanical hand brake
Trailer structure	Single axle
Tire size	14 inches
Leveling jack type	5 x Manual

## ■ Controller Panel Specification

Control module	<b>SMARTGEN</b> HGM1790N
Main & Lamps Breaker	<b>DELIXI</b>
Emergency stop	Equipped
Starting method	Electric (Key start/Button))
Output Socket	2 x Single phase

# GLT4000-8HY

Powered by  **YANMAR**

**Genlitec**<sup>®</sup>  
Power & Lighting Solutions

## LED Lights Detailed Technical Data

Image



Dimension

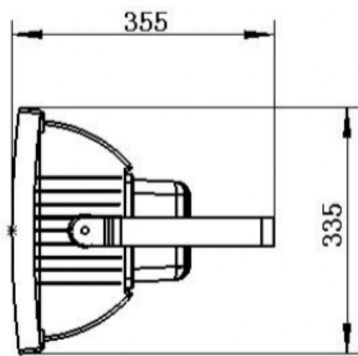

Description	Metal halide lamps
Model number	FG13611
Light power	1000W
Bulb model	MH1000/TT76/4200K/E39
Ballast model	MH1000W M47
Installation method	"U" type holder
Working temperature	-30°C ~ 40°C
Rated voltage	AC 120-277V
Rated frequency	50/60Hz
Power factor	Ⓡ ≥0.90
Design lifetime	10000 hours
Protection grade	IP65
Certificates	CE/ROHS
Light cover material	Aluminum
Lighting angle	90°
Luminous efficacy	75Lm/W
Luminous flux	75,000Lm@4200K
Color temperature	4200±300K

## Lighting Performance

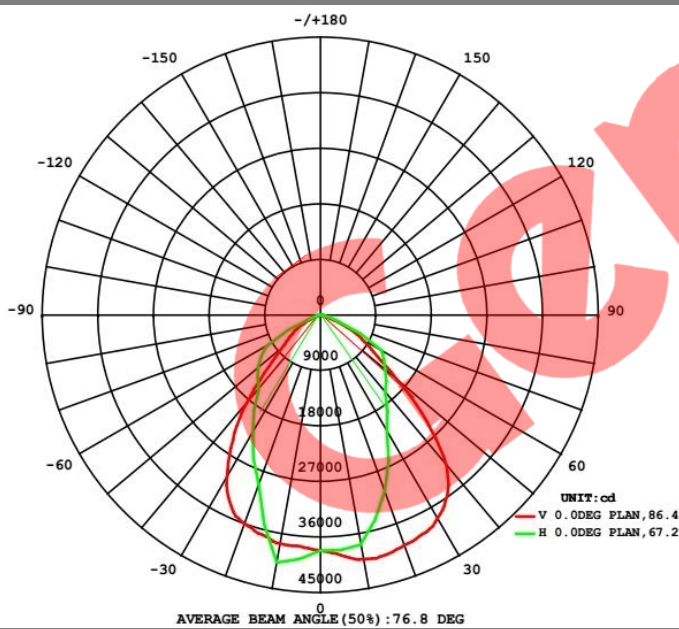

## Standard Supply Scope

- Industrial exhaust silencer
- Maintenance free battery
- Water cooling radiator
- A.V.R
- Weatherproof canopy
- Flexible pipes
- Battery wires
- Wiring diagram
- Build-in based fuel tank
- Top caution light
- Float Battery charger
- Manual books
- Ball/Ring hitch with safe chain
- Emergency stop button
- Base frame
- Digital control panel
- Main circuit breaker
- Power output socket x 2

## Optional Supply Scope

Engine	AC Alternator	Control Panel	Lamps	Others
<input type="checkbox"/> Yanmar 3TNV88	<input type="checkbox"/> Stamford	<input type="checkbox"/> Smartgen ALC404	<input type="checkbox"/> 4x350W LED	<input type="checkbox"/> Security camera
<input type="checkbox"/> Perkins 403D-11G	<input type="checkbox"/> Mecc Alte	<input type="checkbox"/> Smartgen ALC704	<input type="checkbox"/> 4x400W LED	<input type="checkbox"/> Grounding rod
<input type="checkbox"/> Yanmar 3TNV88		<input type="checkbox"/> Smartgen ALC708	<input type="checkbox"/> 4x480W LED	<input type="checkbox"/> Water-jacket heater
<input type="checkbox"/> Quanchai QC380D		<input type="checkbox"/> ComAp LTC 80		<input type="checkbox"/> Battery isolator
		<input type="checkbox"/> Wi-Fi router (4G SIM)		<input type="checkbox"/> Fire Extinguisher
		<input type="checkbox"/> Remote control & monitoring system		<input type="checkbox"/> Wheel chocks
				<input type="checkbox"/> Reflector set
				<input type="checkbox"/> Trailer VIN number

# GLT4000-8HY

Powered by  **YANMAR**

## Control Panel

### Configuration

- Emergency stop button
- Protection MCB + Lamps & Socket circuit breaker
- Digital control module
- Power output socket x 2 (Single Phase)
- Controller box
- Alarm buzzer





### Key Features

- Large back-lit icon LCD display
- Single / Three phase generator monitoring
- AC phase voltage display
- Generator frequency display
- Engine speed RPM display
- Battery voltage Vdc display
- Generator running hours display
- Engine coolant temperature display
- Engine oil pressure display
- Pre-alarm & shutdown alarm function
- Low oil pressure shutdown alarm
- Engine high temperature shutdown alarm
- Engine over speed shutdown alarm
- Generator over/under voltage shutdown alarm
- Generator overload shutdown alarm
- Start/Stop failure shutdown alarm
- IP65 rating offers increased resistance to water ingress

### Control Module: SMARTGEN HGM1790N

Digital input	5
Relay output	5
Communication interface	PC
AMF	N/A
AC System	1P2W / 2P3W / 3P3W / 3P4W
Phase voltage input	0-300Vac
Frequency range	3Hz – 70Hz
Standby current	TBA
Accuracy	1%
Control relay outputs	3A/30Vdc
DC supply	DC 8-35V
Operating temp.	-20 ~ +70°C

## Controller Module Options

Smartgen	Smartgen	ComAp
ALC404	ALC704/708	IntelliLite LTC 80
		

Local Distributor / Partner

